

COTAS SIN TOLERANCIA/DIMS WITHOUT TOLERANCE (mm)		
Más de/Bigger than	hasta/up to	Tolerancia/Tolerance
0,5	6	±0,1
6	30	±0,2
30	120	±0,3
120	315	±0,5
315	1000	±0,8

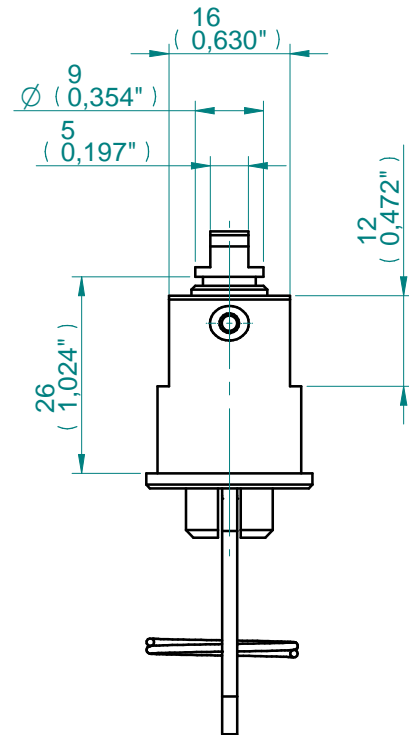

	Fecha/Date	Firma/Signature					
Dibujado/ Drawn by	30-05-05	JOKIN					
Revisado/ Checked by			Fecha/Date	Nombre/ Name	Indice/ Index	Letra/ Letter	Cambio / Change
Material	Tratamiento térmico/Heat treatment		Trat. protección superficial/Surface treatment				
Peso/Weight	Designación de la pieza / Part name				Nº de la pieza/Part number	Edición/Edition	Escala/Scale
0,0 kg	BOMBILLO DE SERRETA INTERCAM. DERECHO/ INTERCHANGEABLE CYLINDER SOLID BRASS (WET AREAS) RIGHT HAND				0317.D05	01	1:1

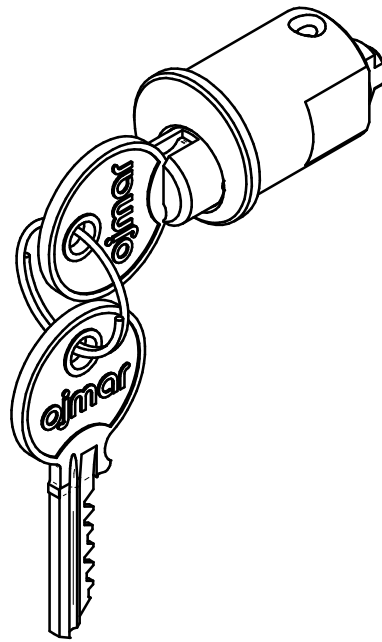
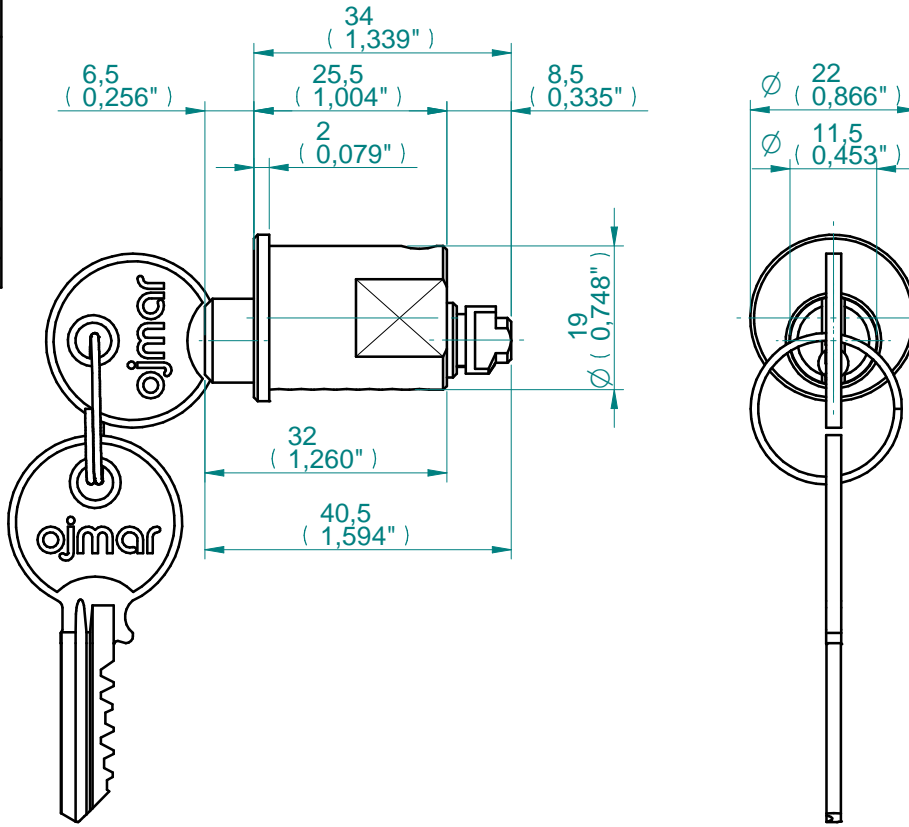

Sustituye a /Substitutes to:	-
Sustituido por /Substituted by:	-